

SAFETY & WARNINGS

1. Install in accordance with national and local electrical code regulations.
2. This product is intended to be installed and serviced by a qualified, licensed electrician.
3. Do not modify or disassemble this product beyond instructions or the warranty will be void.
4. Do not submerge, or install within 5 feet of a swimming pool.
5. Only install with a Listed Class 2 DC LED driver.
6. To avoid Voltage Drop, ensure wire gauge used with LED Strip Light is sufficient to keep under 3% voltage drop.
7. Do not exceed maximum run recommended for Strip Light.
8. Diode LED Strip Light is designed to be cut at designated cut points only. Cutting anywhere other than the cut points will result in damage to the Strip Light.
9. Failure to follow safety warnings, and installation instructions will void the warranty for this product.

QUICK SPECS

Input Voltage	See Package Label
Power Consumption	
Maximum Run	
Environment	
Included Models ¹	DI-12V-**, DI-24V-**
Ambient Temperature ²	-4° ~ 122°F (-20° ~ 50°C)

Note ¹ ** Indicates luminaire family, CCT, CRI, length.

Note ² Do not install product in an environment outside the listed ambient temperature.

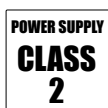
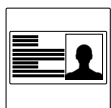

Low Voltage Tape Light

INSTALLATION GUIDE



WARNING!

DO NOT CONNECT DIRECTLY TO HIGH VOLTAGE POWER!

Read all warnings and installation instructions thoroughly.

HANDLE PRODUCT WITH CARE!

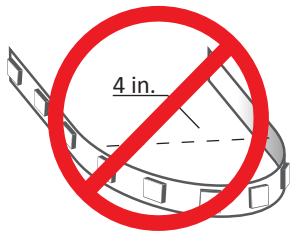

DO NOT BEND LED STRIP LIGHT TO A DIAMETER LESS THAN 4 INCHES.

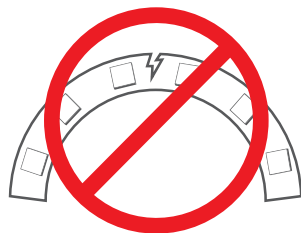

DO NOT BEND LED STRIP LIGHT ON A HORIZONTAL PLANE.

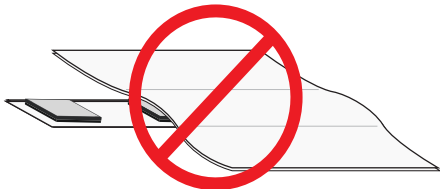

DO NOT COVER STRIP LIGHT WITH ANY MATERIALS.

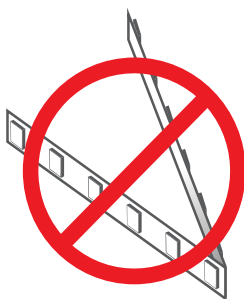

DO NOT FOLD, CREASE, OR TWIST LED STRIP LIGHT.

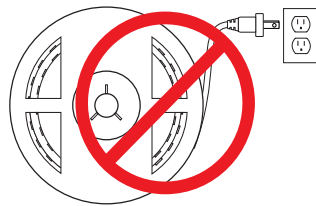

DO NOT POWER STRIP LIGHT WHILE ATTACHED TO SPOOL OR TIGHTLY COILED.

INSTALLATION

Prior to installation, verify all components (LED Tape, Driver, Control, & Accessories) are compatible. Configure and pre-test your LED system prior to installation to ensure all components are operating correctly.

1 TURN POWER OFF AT CIRCUIT BREAKER



SHOCK HAZARD! May result in serious injury or death.

Turn power OFF at circuit breaker prior to installation.

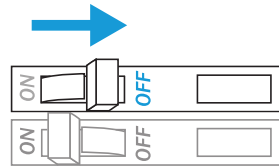

2 DETERMINE LOCATION TO INSTALL COMPONENTS

Refer to **SYSTEM DIAGRAMS**.

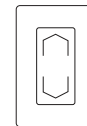
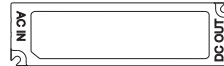

1) Class 2 Driver

2) Control

3) Tape Light

WIRE GAUGE & VOLTAGE DROP

Ensure applicable wire is installed between driver, fixture, and any controls in between. When choosing wire, factor in voltage drop, amperage rating, and type (in-wall rated, wet location rated, etc.)

Low Voltage Tape Light

INSTALLATION GUIDE

INSTALLATION (CONT.)

3 CUT TAPE LIGHT TO DESIRED LENGTH

Cut at line indicated with scissors icon.

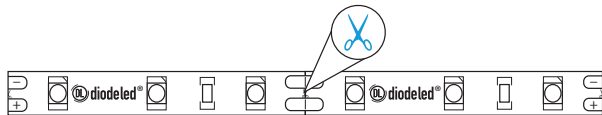

4 TEST CONNECTION



Prior to mounting, attach to Class 2 LED Driver, turn on power and test connection to ensure system is operating properly. Turn off power again before mounting.

5 MOUNT TAPE LIGHT

Clean surface before mounting. See below for mounting **DRY LOCATION** and **WET LOCATION** Models.

a) DRY LOCATION TAPE LIGHT

5.1 Peel off 3M™ Adhesive Backing. *Ensure ambient temp is minimum 50 ° F (10 ° C) or tape will not adhere properly.*

Tear off backing along connector edge.

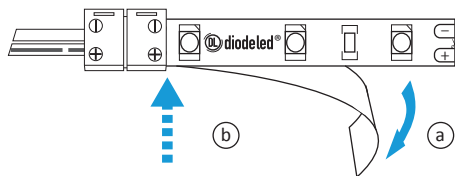

5.2 Adhere to a smooth, dry surface, working one end to the other.

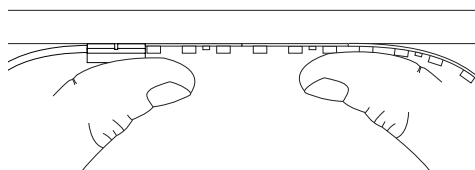

5.3 Use plastic Tape Light Fasteners (not included) to secure tape to surface.

DO NOT PLACE FASTENER ON LED CHIPS/RESISTORS!

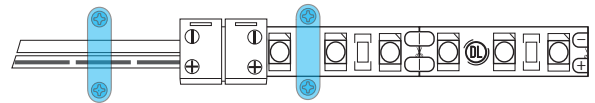

Ex. BLAZE™ Tape Light pictured.

5 MOUNT TAPE LIGHT (CONT.)

b) WET LOCATION TAPE LIGHT

5.4 Use MALE and FEMALE wet location connectors to attach cut sections of wet location tape in series.

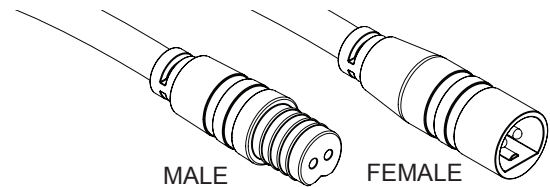

5.5 All cut sections must be sealed with *non-acidic neutral silicone sealant/adhesive* (Diode SKU: DI-WPSL not included), and wet location end caps. Acidic-based adhesives may damage the phosphor of LED chips.

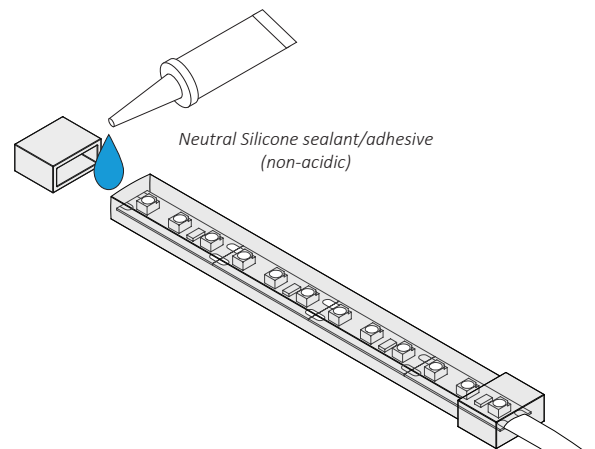

Low Voltage Tape Light

INSTALLATION GUIDE

INSTALLATION (CONT.)

- 5.6** Mount with included mounting clips/screws. Silicone adhesive can also be utilized to mount tape to surfaces.

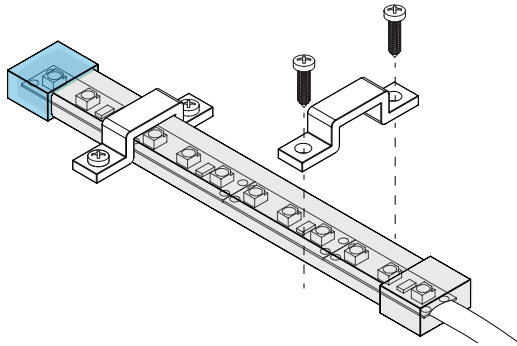

6 ATTACH DRIVER AND LIGHTING CONTROL

ONLY USE COPPER WIRING. See **SYSTEM DIAGRAMS** on pages 6-7. Verify a compatible driver and control are installed.

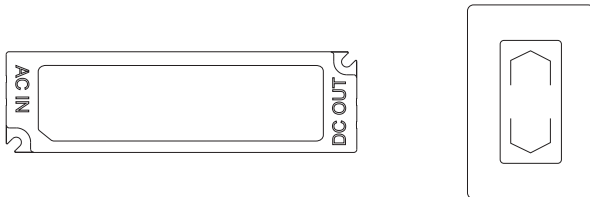

REVIEW FULL SYSTEM and ensure all polarities are correct and connections are secure.

7 TURN POWER ON AT CIRCUIT BREAKER

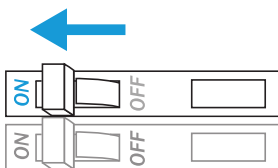

SYSTEM WORKING IMPROPERLY?

Turn power OFF at circuit breaker and verify all connections. Review SYSTEM DIAGRAMS and TROUBLESHOOTING or call Diode LED Technical Support at 877.817.6028.

CLICKTIGHT INSTALLATION



CLICKTIGHT LOAD LIMIT
12VDC: 60W, 5A / 24VDC: 100W, 4.17A

CLICKTIGHT COMPATIBILITY

CLICKTIGHT MODEL	8mm (Window)	10mm (No Window)	RGB (No Window)	RGBW (Window)
TAPE LIGHT	AVENUE 24™ BLAZE™ FLUID VIEW®	ULTRA BLAZE™ VALENT® VALENT® HD	DAZZLE® RGB	DAZZLE® RGBW DAZZLE® RGBW 4D

1 CUT TAPE LIGHT

Cut at line indicated with scissors icon.

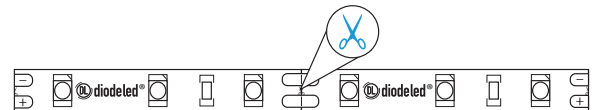

2 INSERT TAPE LIGHT INTO CLICKTIGHT

Determine orientation of tape light for correct polarity.

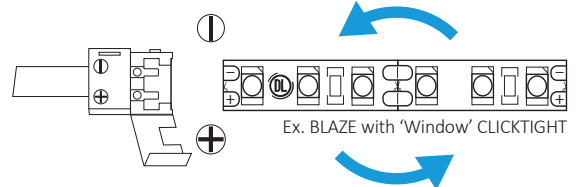

Determine orientation of tape light for correct polarity.

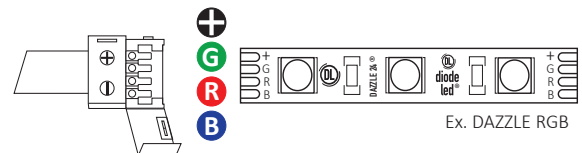

Low Voltage Tape Light

INSTALLATION GUIDE

CLICKTIGHT INSTALLATION (CONT.)

Remove 3M™ adhesive backing and insert tape light into connector and close connector.

Note: Contact/solder points of tape light MUST be directly underneath metal conductors of CLICKTIGHT. **DO NOT place tape light on top of metal conductors!**

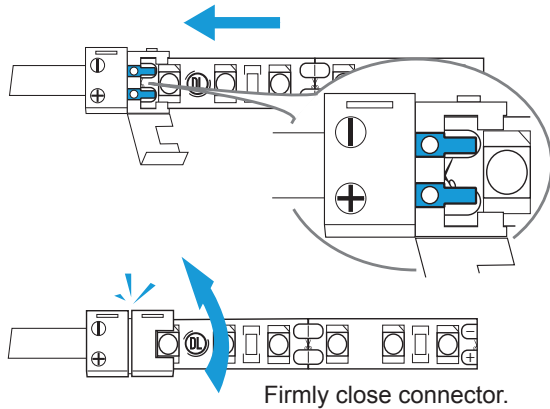

3 MOUNT TAPE LIGHT

Install on a smooth, finished, dry surface. Prep surface to removed dust and dirt before mounting.

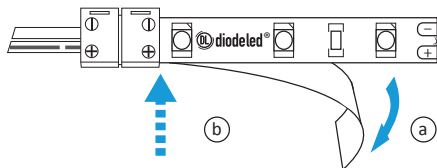

- 1) Remove 3M™ adhesive backing.
- 2) Tear off along connector edge (this allows for a tighter fit for 'No Window' models). Mount tape light to surface, working one end to the other.

DOUBLE BLAZE CONNECTOR INSTALLATION

These instructions apply only to Double LED Tray Connectors. Never cut tape attached to a live circuit. Do not exceed Class 2 Limit when loading Double Blaze Connectors.

1 CUT TAPE LIGHT TO DESIRED LENGTH

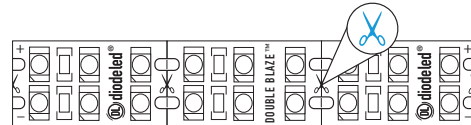

Cut at the line indicated with scissors icon.

2 PULL BLACK TAB

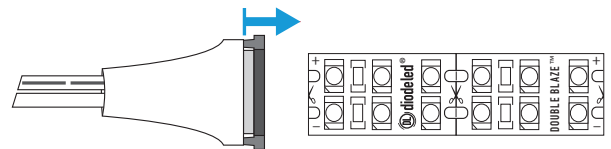

Gently pull out the black tab 1-2mm. Note the +/- polarity markings of the tape light.

3 INSERT TAPE LIGHT INTO CONNECTOR

Firmly insert with 3M™ Adhesive backing still intact to Tape Light.

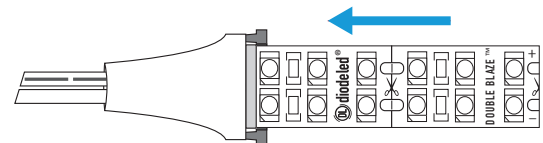

Ensure contact/solder points of tape light are directly underneath white/gray tab of connector tray.

4 FIRMLY CLOSE CONNECTOR TRAY

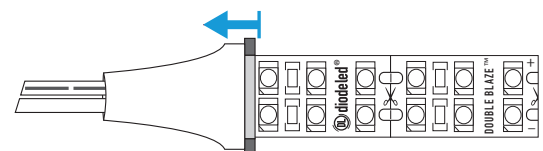

Proceed to **INSTALLATION - STEP 4 - TEST CONNECTION** on page 2.

Low Voltage Tape Light

INSTALLATION GUIDE

VALENT X CONNECTOR INSTALLATION

These instructions apply only to Valent X Connectors. Never cut tape attached to a live circuit. Do not exceed Class 2 Limit when loading Valent X Connectors.

1 CUT TAPE LIGHT TO DESIRED LENGTH

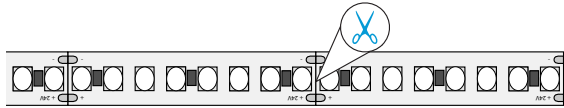

Cut at the line indicated with scissors icon.

2 OPEN CONNECTOR

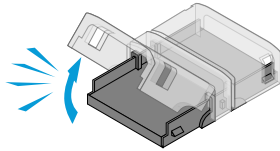

Gently pull open connector window. Note the +/- polarity markings of the tape light.

3 INSERT TAPE LIGHT INTO CONNECTOR

Firmly insert with 3M™ Adhesive backing still intact to Tape Light.

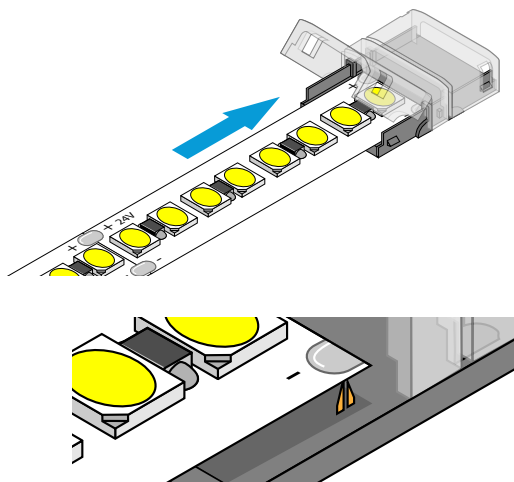

Ensure contact/solder points of tape light are directly over connection prongs within connector.

4 FIRMLY CLOSE CONNECTOR TRAY

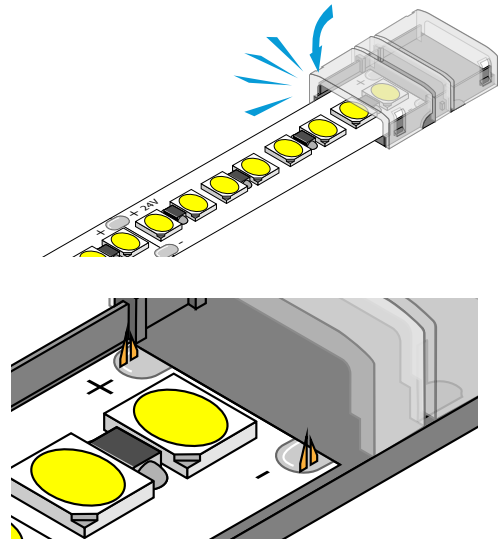

Ensure connection prongs pierce completely through Valent X LED Tape Light.

Proceed to **INSTALLATION - STEP 4 - TEST CONNECTION** on page 2.

Low Voltage Tape Light

TROUBLESHOOTING

Symptom	Common Cause
Tape Light does not illuminate	<ul style="list-style-type: none"> Circuit breaker is OFF or tripped. Incorrect wiring. Polarity of Low Voltage V+ and V- are reversed. Check connection at every connection point to ensure polarity is not reversed. Incorrect voltage pairing of LED driver and fixture. 12V driver models will not power a fixture with a higher voltage rating.
Tape Light Overheats	<ul style="list-style-type: none"> Incorrect voltage pairing of LED driver and fixture. Ensure 12V tape light models are not paired with a driver with higher voltage. Incorrect ambient temperature. Ensure tape light is installed in environment $-4^{\circ} \sim 122^{\circ}\text{F}$ ($-20^{\circ} \sim 50^{\circ}\text{C}$).
Fixture flickers randomly, may shut off	<ul style="list-style-type: none"> Connection is not secure. Check connection at CLICKTIGHT and ensure metal prongs of CLICKTIGHT are directly on top of Tape Light Solder pads.
Shift in brightness and/or color	<ul style="list-style-type: none"> Review Tape Light maximum series run limit. Exceeding will cause voltage drop, decreasing brightness and/or color shift. Review Voltage Drop Charts on pg. 8. Incorrect wire gauge may cause voltage drop and noticeable shift in brightness and/or color.
Tape Light turns on/off repeatedly	<ul style="list-style-type: none"> Driver is overloaded or overheated. An overloaded/overheated driver will trip the internal auto-reset (of driver) repeatedly, turning the system on/off.
CLICKTIGHT Connectors	<ul style="list-style-type: none"> Ensure compatible CLICKTIGHT models are attached. Tape lights vary in width and require specific connectors. Contact your supplier for additional information. Tape Light is polarity sensitive. Ensure V+ of power is attached to V+ of tape light. Ensure V- of power is attached to V- of tape light.

VOLTAGE DROP CHARTS

For best performance and lumen output, ensure proper wire gauge is installed to compensate for voltage drop of low voltage circuits.

12V Voltage Drop & Wire Length Distance Chart

Wire Gauge	10 W .83 A	20 W 1.7 A	30 W 2.5 A	40 W 3.3 A	50 W 2.1 A	60 W 4.2 A
20 AWG	18 ft.	9 ft.	6 ft.	5 ft.	4 ft.	3 ft.
18 AWG	34 ft.	17 ft.	11 ft.	8 ft.	6 ft.	5 ft.
16 AWG	54 ft.	27 ft.	18 ft.	13 ft.	10 ft.	9 ft.
14 AWG	86 ft.	43 ft.	29 ft.	21 ft.	17 ft.	14 ft.
12 AWG	134 ft.	68 ft.	45 ft.	34 ft.	27 ft.	22 ft.
10 AWG	199 ft.	99 ft.	66 ft.	49 ft.	39 ft.	33 ft.

Voltage Drop Chart Guide

- 1 Determine load size. Let's assume load is 55 W. Round up to nearest load.
- 2 Determine distance from driver to load. Let's assume the distance is 20 ft.
- 3 It's recommended to install 12 AWG to eliminate excess voltage drop.

24V Voltage Drop & Wire Length Distance Chart

Wire Gauge	10 W .42 A	20 W .83 A	30 W 1.3 A	40 W 1.7 A	50 W 2.1 A	60 W 2.5 A	70 W 2.9 A	80 W 3.3 A	90W 3.75 A	100 W 4.2 A
20 AWG	85 ft.	43 ft.	27 ft.	21 ft.	17 ft.	14 ft.	12 ft.	11 ft.	9 ft.	8 ft.
18 AWG	134 ft.	68 ft.	45 ft.	33 ft.	27 ft.	22 ft.	19 ft.	17 ft.	15 ft.	14 ft.
16 AWG	215 ft.	109 ft.	72 ft.	54 ft.	43 ft.	36 ft.	31 ft.	27 ft.	24 ft.	22 ft.
14 AWG	345 ft.	174 ft.	115 ft.	86 ft.	69 ft.	57 ft.	49 ft.	43 ft.	39 ft.	36 ft.
12 AWG	539 ft.	272 ft.	181 ft.	135 ft.	108 ft.	90 ft.	77 ft.	68 ft.	61 ft.	56 ft.
10 AWG	784 ft.	397 ft.	263 ft.	197 ft.	158 ft.	131 ft.	112 ft.	98 ft.	97 ft.	82 ft.

Low Voltage Tape Light

INSTALLATION GUIDE

SYSTEM DIAGRAMS

The following diagrams are provided as example system designs. For information regarding larger systems or systems not pictured below, please see our web page or contact technical support. Always review each component installation guide for detailed and up-to-date wiring instructions. Install in accordance with national and local electrical codes.

SINGLE COLOR CONTROL SYSTEMS

Traditional ON/OFF Switch System

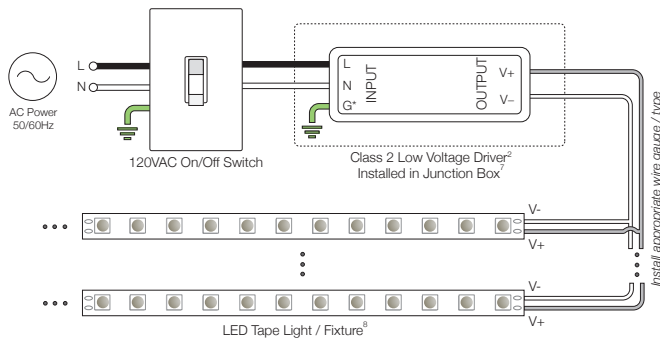

SWITCHEX® Dimmer/Driver System

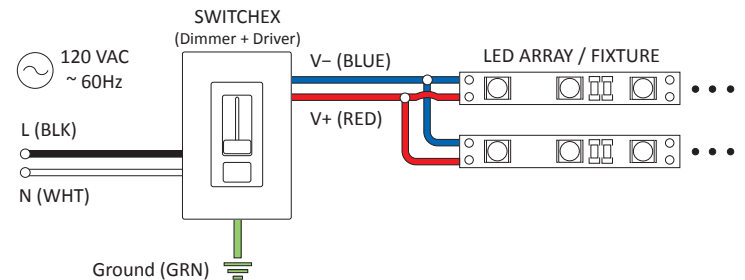

OMNIDRIVE® Electronic Dimmable Driver System

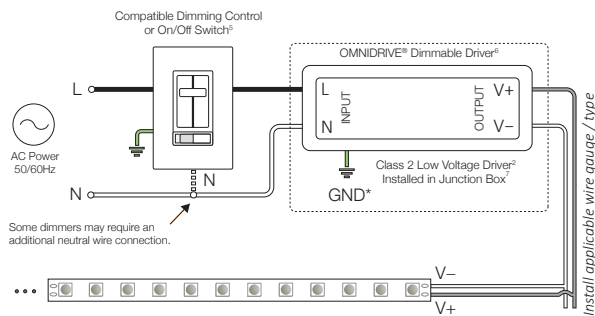

REIGN® 24V Dimmer System

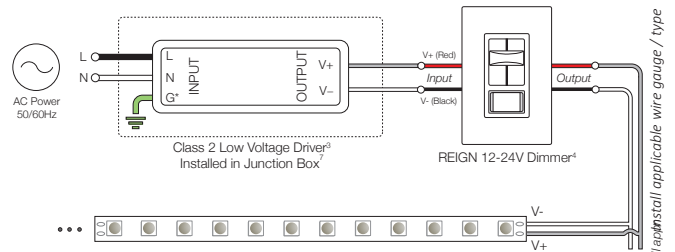

1. Driver may not require a fault ground connection. Refer to driver specifications for additional information.
2. Install a compatible Class 2 constant voltage driver. Refer to each driver specification sheet for full power ratings & load deratings.
3. Install a Class 2 constant voltage driver compatible with a low voltage PWM controller/dimmer switch. Refer to each driver specification sheet for full power ratings & load deratings.
4. Determine the number of low voltage outputs of the driver when installing multiple PWM controllers/dimmer switches. No more than one PWM controller/dimmer switch can be attached to a single output of the driver.
5. Install a compatible dimming control or switch. See the 'Electronic Dimmable Driver / Dimmer Compatibility List' for compatible dimming controls. See the dimming control manufacturer installation guide for complete wiring instructions.
6. Ensure to load the driver at least 60% of the labeled load for proper dimming performance (required for dimmable installations only).
7. Refer to driver or controller specifications for a compatible junction box.
8. See fixture specifications for maximum series run limits.

Low Voltage Tape Light

INSTALLATION GUIDE

SYSTEM DIAGRAMS (CONT.)

RGB/RGBW COLOR CONTROL SYSTEMS

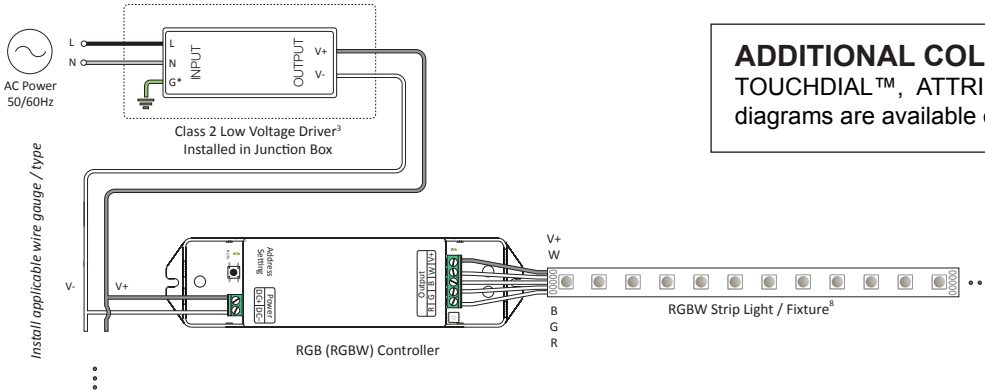

ADDITIONAL COLOR CONTROL SYSTEMS
TOUCHDIAL™, ATTRIBUTE™, and other control system diagrams are available on-line at www.DiodeLED.com.

DMX CONTROL SYSTEM

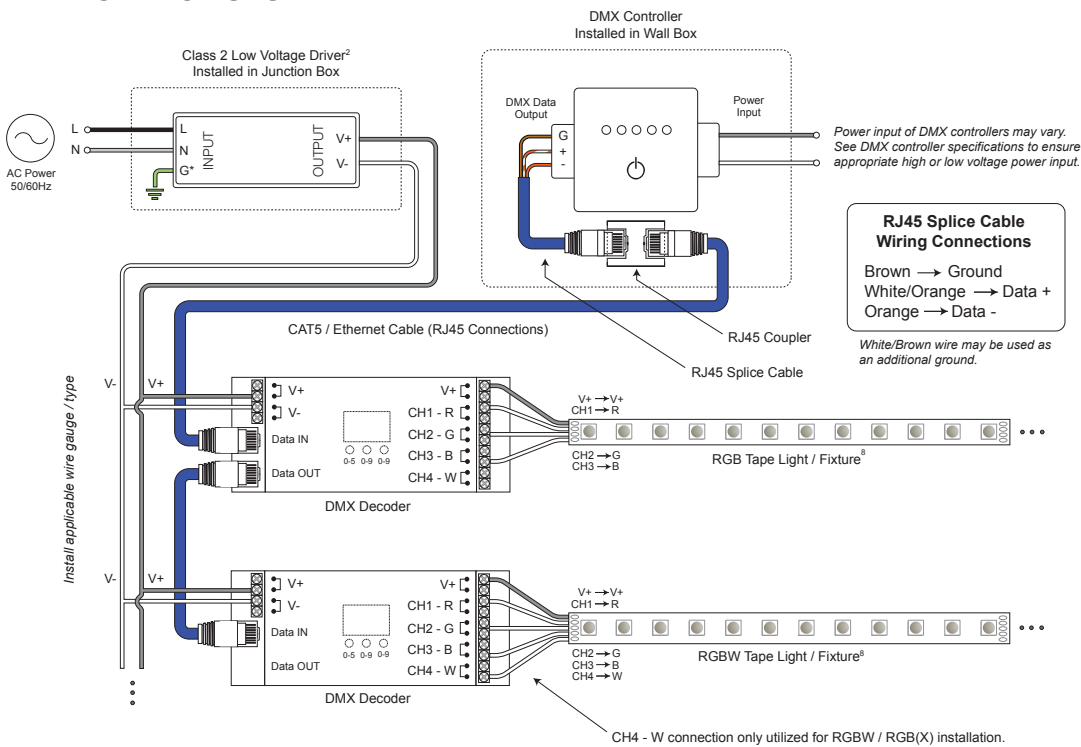

ADDITIONAL RESOURCES

Visit the on-line product page at www.DiodeLED.com for individual LED Tape Light product specifications & warranty information.



Toll Free: 877.817.6028 | Fax: 415.592.1596 | www.DiodeLED.com | info@DiodeLED.com
© 2018 Elemental LED, Inc. All rights reserved. Specifications are subject to change without notice.